

Designed for testing ambient air quality in households, public real estates or other properties where doubts of impurity exist.



INDOOR AMBIENT AIR MICROBE SAMPLING DEVICE



- For ambient air microbe sampling
- Three samples at the same time
- Remarkable time saving compared to a traditional method

ISO 9001:2008

ISO 14001:2004

DEVICE

Vacuum pump

Flow meters with flow adjustment valves

Integrated time switch system

Compatible hoses with quick connectors

Andersen-type six stage viable cascade impactors

OPTION

NOTE! The culture plates for the impactors are not included in the delivery, they must be purchased locally.

Flow range for chemical sampling (VOC)

TYPICAL APPLICATIONS

Examining fungal contamination in case of moisture damage

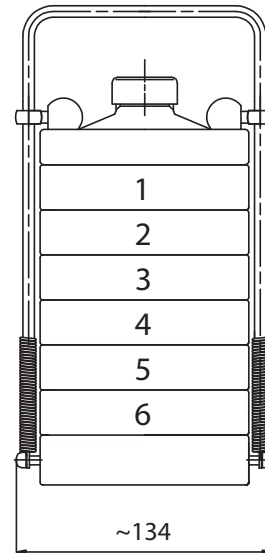
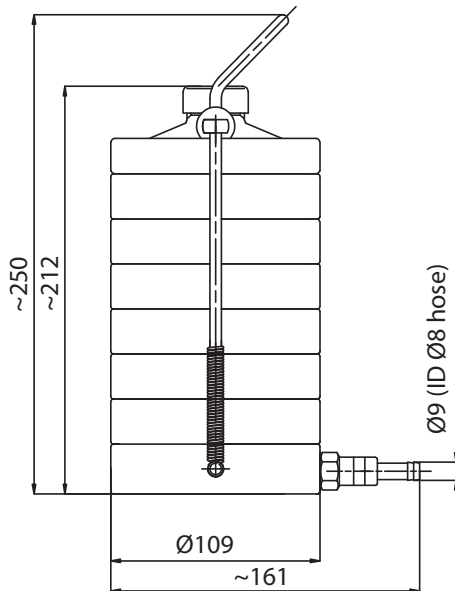
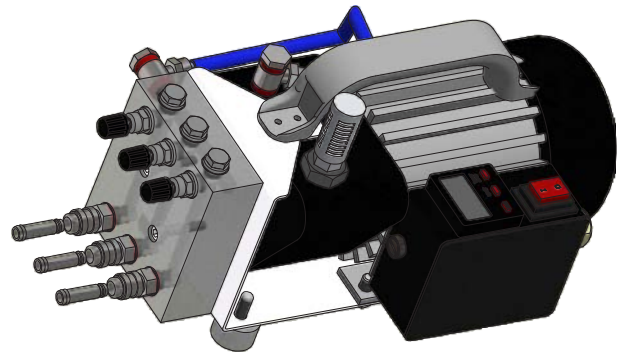
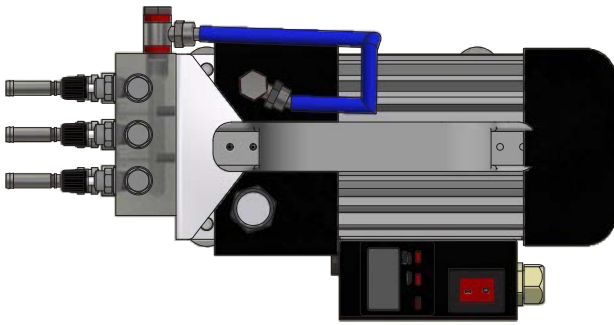
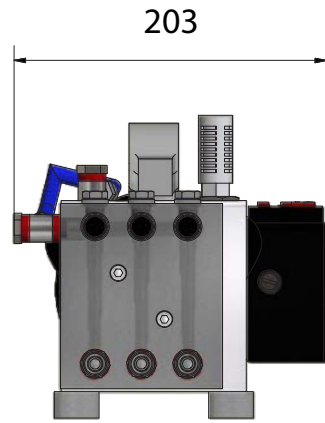
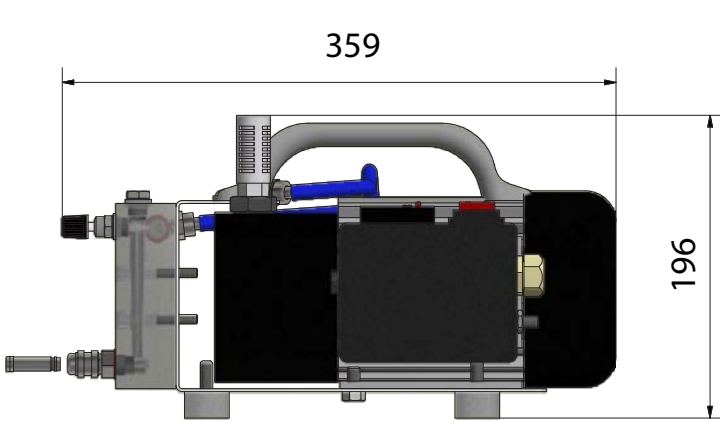

Andersen-type six stage viable cascade impactors