

The KYTOLA® variable area flow meter models A, C and D are clear, easy to read acrylic flow meters.

They are reliable instruments for measuring and monitoring liquid and gas flows.



FLOW METER A, C, D

- For liquid or gas
- Flow ranges from 2 – 20 mL/min up to 10 – 100 L/min (H₂O)
- Flow ranges from 0.1 – 0.9 NL/min up to 500 – 2500 NL/min (Air)
- Maximum pressure 20 bar (30 bar/30°C)
- Maximum temperature 75°C

FEATURES

- Machined acrylic body
- Clear, easy to read scales

TYPICAL APPLICATIONS

- Water treatment
- Sealing water measurements
- Gas flow measurements

OPTIONS

- Scales for alternative liquids and gases
- Special scale markings
- Thread adapters

Model

A

Connections

BSP 3/8", thread adapters must be used for NPT connections

Body

Acrylic (PMMA)

Max. pressure

20 bar (30 bar/30°C)

Max. temperature

75°C

Weight

190 g

Accuracy

±5% F.S. (H₂O, +20°C)A - Flow Range
H₂O

Air

2 – 20 mL/min	0.1 – 0.9 NL/min	2K
4 – 34 mL/min	0.1 – 1.3 NL/min	2A
5 – 60 mL/min	0.2 – 2 NL/min	2B
10 – 95 mL/min	0.4 – 2.8 NL/min	2C
0.01 – 0.13 L/min	0.5 – 6.5 NL/min	3K
0.02 – 0.22 L/min	0.5 – 8 NL/min	3A
0.02 – 0.36 L/min	1 – 11 NL/min	3B
0.05 – 0.5 L/min	1 – 14 NL/min	3C
0.1 – 1.1 L/min	4 – 30 NL/min	8M
0.2 – 1.8 L/min	5 – 50 NL/min	8P
0.2 – 2.6 L/min	5 – 75 NL/min	8S
0.25 – 3 L/min	10 – 90 NL/min	8R
0.5 – 5 L/min	10 – 150 NL/min	5A
0.5 – 6.5 L/min	20 – 220 NL/min	8D

Scale

H₂O (L/min) at +20°C

Air (NL/min) at +20°C/101.3 kPa

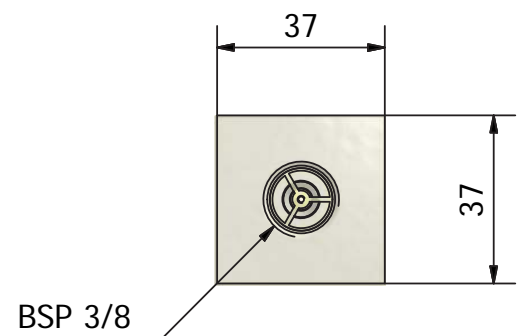
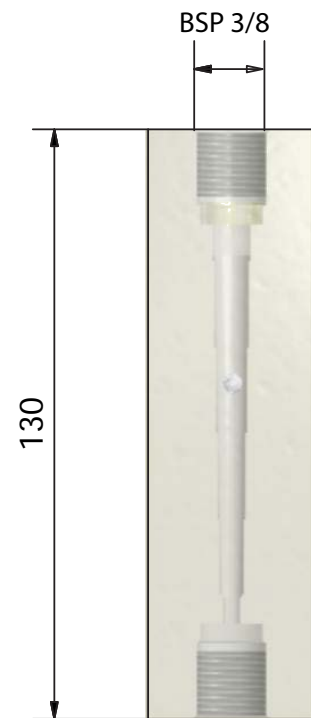
A
R

Model

C

Connections

BSP 3/4", thread adapters must be used for NPT connections

Body

Acrylic (PMMA)

Max. pressure

20 bar (30 bar/30°C)

Max. temperature

75°C

Weight

510 g

Accuracy

±5% F.S. (H₂O, +20°C)

C -

Flow Range

H₂O

Air

0.5 – 5 L/min	20 – 200 NL/min	4A
1 – 8.5 L/min	25 – 250 NL/min	4B
1 – 10 L/min	25 – 300 NL/min	4C
2 – 16 L/min	75 – 450 NL/min	4D
2 – 20 L/min	50 – 600 NL/min	4E
5 – 30 L/min	100 – 1000 NL/min	4F

Scale

H₂O (L/min) at +20°C

Air (NL/min) at +20°C/101.3 kPa

A

R

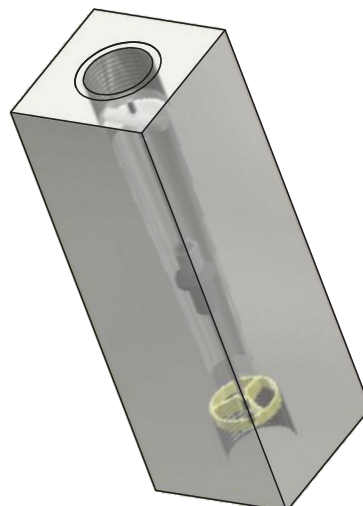
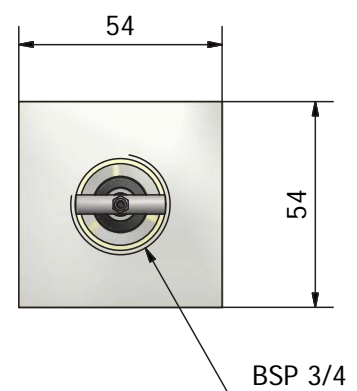
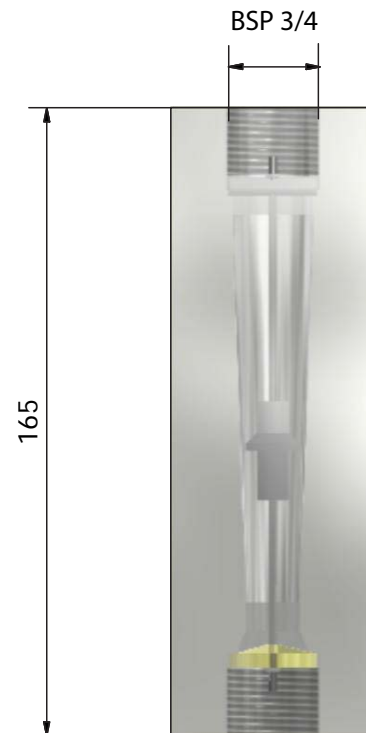

D

TECHNICAL DATA

Model

D

Connections

BSP 1", thread adapters must be used for NPT connections

Body

Acrylic (PMMA)

Max. pressure

20 bar (30 bar/30°C)

Max. temperature

75°C

Weight

620 g

Accuracy

±5% F.S. (H₂O, +20°C)

D -

Flow Range
H₂O

Air

7.5 – 40 L/min	200 – 1200 NL/min	4A
7.5 – 50 L/min	200 – 1400 NL/min	4B
10 – 60 L/min	300 – 1500 NL/min	4C
10 – 80 L/min	300 – 2100 NL/min	4D
10 – 100 L/min	500 – 2500 NL/min	4E

Scale

H₂O (L/min) at +20°C

A

Air (NL/min) at +20°C/101.3 kPa

R

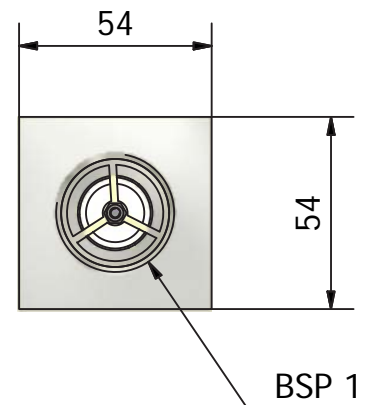
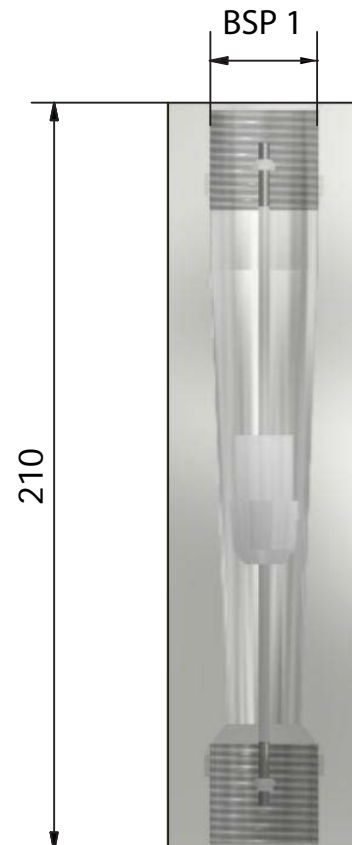
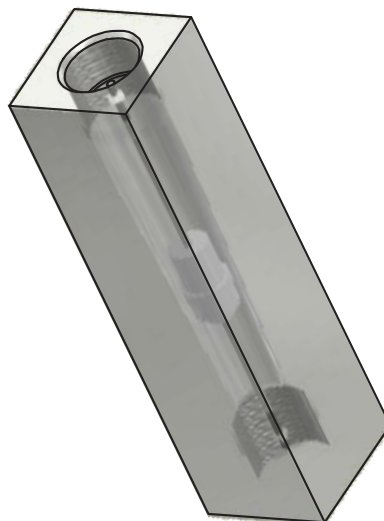

Kytola
INSTRUMENTS

www.kytola.com

Kytola Instruments Oy
Olli Kytölään tie 1
FI-40950 Muurame, Finland
Tel. +358 20 779 0690
Fax +358 14 631 419
E-mail info@kytola.com